

S3-105PM 105kW Three Phase Power Controller – Panel Mounting



The Power Products range of S3 thyristor power controllers are designed for the control of resistive loads in electric furnaces, and heater batteries in HVAC systems.

The S3 power controller series uses zero crossover switching. Burst Pulse Control ensures the load is switched only in multiples of a complete mains half-cycle in order to keep supply and electrical disturbance to a minimum. The units also feature variable frequency PWM for near infinite resolution.

Features

- 0 – 10V Input Control
- 105kW Output
- PWM Control
- Zero Cross Over Switching
- AUTO / MANUAL Override
- Self-Powered
- Panel Mounting
- IP20 Rating
- CE Compliant
- BSEN50178 Build Standard

Specifications and Characteristics

Type Number	S3-105PM
Order Code	21-1448/01
Total Rating (kW)	105
Maximum Current rms (A)	146
Losses (W)	288
Supply Voltage (Vac)	415 -15+10%
Frequency (Hz)	50 - 60
Power Supply	Line / Self Powered
Controlled Arms	Two
Cooling	Natural Air Convection
Fuse Type	315FM
Terminal mm ²	35
AUTO / MANUAL Override	YES
Input Signal (Vdc)	0-10
Input Impedance (ohms)	47K
Cycle Time (S)	0.4 at 50% output rising to 1 at 0% and 100%
Isolation (V)	3600
Operating Temperature (°C)	-10 to + 40
De rating	20% at 50°C
Dimensions (mm) H	252
W	265
D	159

*Other Three Phase supply voltages may be accommodated – please enquire for details

Implementation & Wiring Information

Typical Three Phase Installation:

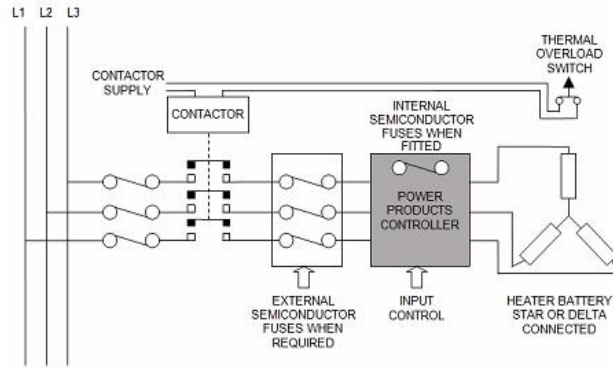

Input Configuration:

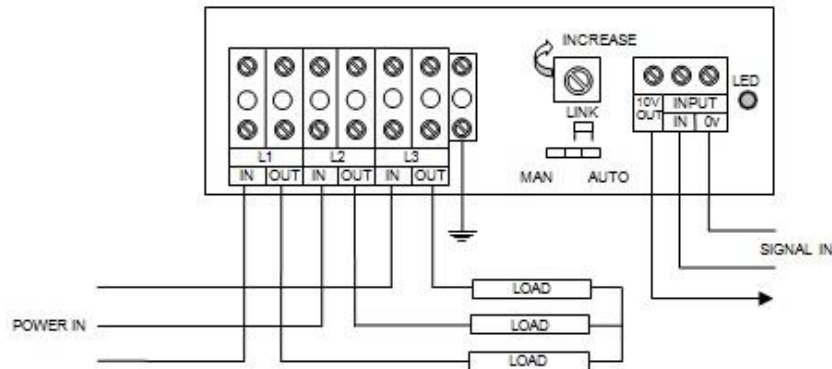

Mechanical Layout:

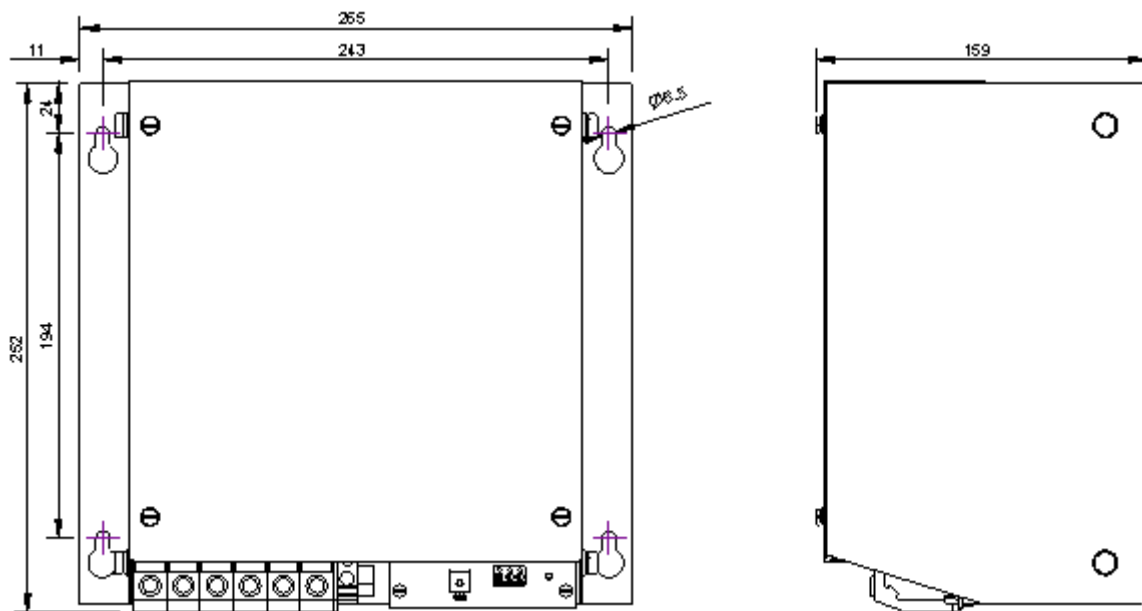

Operational & Safety Instructions

OPERATION

This power controller is designed to regulate a resistive load by switching the load on and off in time proportioned bursts according to the incoming dc signal (Factory set 0-10Vdc).

LOCATION

Install power controller with heatsink fins in the vertical plane. Allow a minimum of 100mm clearance top and bottom, and 25mm horizontally. Control panels should have sufficient ventilation (grills or louvres as required) to maintain the ambient temperature through the thyristor unit to below 40 Degrees C to run unit to specified kW rating.

SAFETY

It is essential to fit a safety device that will disconnect the mains supply from the controller in case the heating element overheats. This can be a suitably rated contactor or circuit breaker. It is also recommended to fit suitably rated fuses for cable protection. (The on board fuses are for controller protection only). Heater batteries should be protected with an over temperature cut-out.

FUSES

Where power controllers are fitted with ultra-fast fuses to protect the semiconductor replacements should be of exactly the same type and should be purchased via your supplier. External fuses may be fitted where not provided, according to normal practice for the protection of wiring etc.

INPUT SIGNAL

These power controllers accept 0 – 10Vdc input signal from a BEMS or controller which will regulate the current to the load in order to achieve accurate proportional control. Therefore load current will be zero, with input signal at zero or disconnected. The unit operates on the burst fire zero-voltage switched principle. Zero voltage switching is for minimum RFI. Burst firing for minimum harmonic distortion. The full load is switched on & off in timed bursts and is proportional to the input signal.

INSULATION TESTS

Thyristors can be irreparably damaged by exceeding their specified voltage rating.

It is therefore important to observe proper insulation testing procedures. The thyristors can be effectively isolated from the circuit by shorting together the line and load terminals. This will protect them from damage due to possible over-voltage caused by the insulation test procedure. The insulation test can then be carried out by applying the test voltage between the line terminals and earth.

Please contact Power Products International Limited if any additional information on this procedure is required.

INSTALLATION

Power Products controllers are designed to be plug and play. Refer to wiring diagram supplied with the controller for correct installation. Before commissioning ensure that ALL power connections are tightened correctly.

It is highly recommended that only a qualified electrician carry out testing due to potentially lethal high voltages associated with this task.