

## DAC3-18 18kW Three Phase Power Controller

---

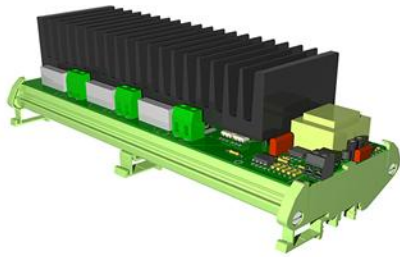

The Spectral range of DIN Rail mounting thyristor power controllers are designed for the control of inductive loads in electric furnaces, and heater batteries in HVAC systems.

The DAC3 series, like all Spectral controllers uses zero crossover switching, and burst pulse control ensures the load is switched only in multiples of complete mains cycles thus keeping supply and electrical disturbance to a minimum.

---

### Features

- 0 – 10V Input Control
- 18kW Output
- PWM Control
- Self Powered
- DIN Rail (TS35) Mounting
- CE Marked

---

### Specifications and Characteristics

BMS Input:	0 – 10V
Supply Voltage:	380 – 440Vac
Frequency:	50/60Hz
Power Supply:	Line / Self powered
Maximum Heater Duty:	18kW
Maximum Load Per Phase:	26 A @ 40°C
Dissipated Heat:	60 W
Operating Temperature Range:	0 – 55°C
Derating:	10% per 5°C above 40°C
Dimensions:	245 x 90 x 80mm (Nom)
Build Standard:	BSEN50178

Country of Origin: United Kingdom

## OPERATION

This power controller is designed to regulate a resistive load by switching the load on and off in time proportioning bursts according to the incoming dc signal (Factory set 0-10Vdc).

## LOCATION

Install power controller with heatsink fins in the vertical plane. Allow a minimum of 100mm clearance top and bottom. Control panels should have sufficient ventilation to maintain the ambient temperature through the thyristor unit to below 40 Degrees C to run unit to specified kW rating.

## SAFETY

It is essential to fit a safety device that will disconnect the mains supply from the Spectral controller in case the heating element overheats. This can be a suitably rated contactor or circuit breaker. It is also recommended to fit suitably rated fuses at the switchboard if a contactor is fitted.

## FUSES

Some power controllers are fitted with ultra-fast fuses to protect the semiconductors. Replacements should be of exactly the same type and should be purchased via your supplier. External fuses may be fitted where not provided.

## INPUT SIGNAL

These power controllers accept 0 – 10Vdc input signals from the BEMS to regulate the current flow to electric heaters or other resistive loads in order to achieve accurate proportional control. The unit operates on the burst fire zero-voltage switched principle. Zero voltage switching is for minimum RFI. Burst firing for minimum harmonic distortion. The full load is switched on & off in timed bursts and is proportional to the input signal.

## INSULATION TESTS

Thyristors can be irreparably damaged by exceeding their specified voltage rating.

It is therefore important to observe proper insulation testing procedures. The thyristors can be effectively isolated from the circuit by shorting together the line and load terminals. This will protect them from damage due to possible over-voltage caused by the insulation test procedure. The insulation test can then be carried out by applying the test voltage between the line terminals and earth.

Please contact Spectral Limited if any additional information on this procedure is required.

## INSTALLATION

Spectral controllers are designed as plug and play. Refer to wiring diagram supplied with the controller for correct installation. Before commissioning ensure that ALL power connections are tightened correctly.

It is highly recommended that only a qualified electrician carry out testing due to potentially lethal high voltages associated with this task

## Thyristor Power Controller DAC3

### Typical Installation Three Phase

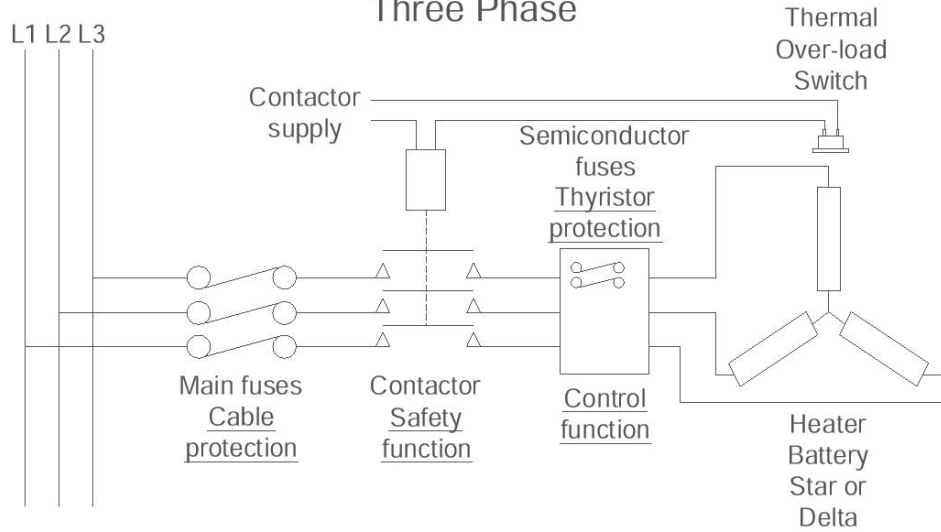

### Input Configuration

